

Mineral Insulated Cable

Product	Description	Page
XACTPAK® Cable	XACTPAK cable is fireproof, high-pressure rated, cold and thermal shock resistant, gas tight, moisture proof, formable, weldable, corrosion resistant and high temperature rated. Diameters down to 0.020 in. (0.5 mm) and temperature ranges from 32 to 2700°F (0 to 1480°C).	193

Mineral Insulated Cable

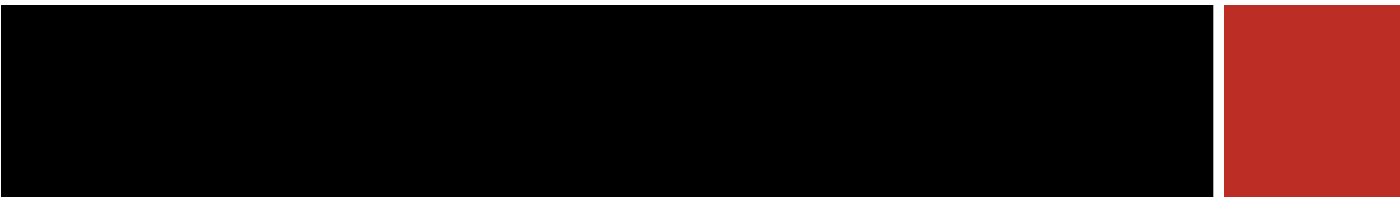



Mineral Insulated Cable

XACTPAK® Cable

Watlow's XACTPAK® mineral insulated, metal-sheathed cable is ideally suited to solve a wide variety of problem applications.

The outer sheath can be made from any malleable metal in a wide range of diameters, containing single or multiple wires. Easily formed or bent, it can accommodate virtually any configuration. The outer sheath protects thermocouple or thermocouple extension wires from oxidation and hostile environments that would quickly destroy unprotected wire.

The mineral insulations available provide excellent high temperature dielectric strength to ensure signals are carried faithfully to the instrumentation or controls.

Performance Capabilities

- Available in standard and special limits of error accuracy
- Diameters from 0.020 to 0.5 in. (0.5 to 12.7 mm)
- Compliance with recognized agency tolerances and specifications
- Sheath materials available to withstand a wide variety of hostile and corrosive environments
- Calibrated for intended temperature range
- Temperature ranges from 32 to 2200°F (0 to 1205°C)
- Cryogenic cable available upon request

Features and Benefits

Fireproof cable

- Performs where conventional insulated wires burn and degrade

Fast and accurate

- Precisely measures temperature for a fast response

Tight moisture and gas seals

- Resists contamination

High pressure rating

- Allows use in pressure vessels and vacuum applications

Form flexibility

- Adapts to virtually any application

Thermal shock resistance

- Withstands thermal cycling

Compact, durable and corrosion resistant

- Ensures long-life performance with minimum constraints on applications

High temperature rating

- Meets demanding application needs

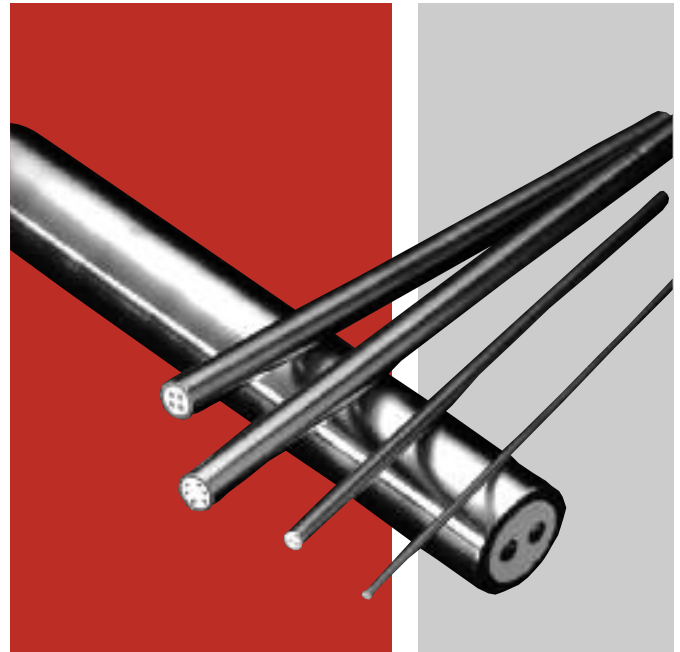

Typical Applications

- Atomic research
- Bearing temperature
- Blast furnaces
- Catalytic reformers
- Diesel engines
- Foodservice and beverage
- Furnaces
- Glass and ceramic
- Heat treating
- Instrument cabling
- Jet engines and test cells
- Kilns
- Laboratory and research
- Medical
- Nuclear reactors
- Power stations and steam generators
- Refineries and oil processing
- Rocket engines
- Semiconductor processing
- Turbines
- Vacuum furnaces

Mineral Insulated Cable

XACTPAK Cable

Technical Data

Quality Control and Testing

To maintain quality and consistency, XACTPAK cable is manufactured under carefully controlled procedures and rigid standards of cleanliness. Quality checks are made at critical points throughout the manufacturing process.

Every coil of XACTPAK cable is thoroughly tested for continuity, insulation resistance, physical dimensions and physical appearance.

Each lot, or batch of XACTPAK, contains raw materials (sheath, insulation, wires) from one production lot which eliminates the need to calibrate every thermocouple cut from a coil because of poor homogeneity. Samples from each lot are calibrated in Watlow's modern calibration laboratory by highly skilled technicians. Unlike some manufacturers who calibrate at a few low temperature calibration points, Watlow calibrates throughout the range that matches the cable's capabilities.

Care, Handling and Fabrication of XACTPAK Cable

To maximize performance advantages made possible by XACTPAK cable's overall premium quality, the following instructions covering its storage, handling and further fabrication should be followed.

Storage

To prevent moisture from being absorbed by its hygroscopic mineral insulation, both ends of each length of XACTPAK cable are sealed at the factory. To further guard against moisture penetration, it is advisable to store XACTPAK material in a dry place.

Moisture

If XACTPAK cable is not adequately sealed, its insulation absorbs moisture. This lowers its electrical resistance and may prove to be troublesome in subsequent welding. Minor moisture penetration can be remedied by using a blow torch to heat the sheath. Apply the flame 6 to 7 inches from the open end and slowly work the flame to and over the end. Reseal the end after it has cooled to about 180°F (82°C). Deep moisture penetration is unlikely, but if it occurs, the material may be baked at approximately 250°F (121°C) for 24 hours to increase its insulation resistance. If baking does not return the insulation resistance to acceptable levels, the material should be discarded.

Cutting

When pieces are cut from a length of XACTPAK cable, the exposed ends should immediately be squared and sealed. Squaring and sealing guards against possible contamination and removes any loosened insulation or distorted wire caused by cutting. A light pressure sanding with a 180-grit belt is the easiest method for rough squaring of 0.040 in. (1.016 mm) or larger diameter XACTPAK cable. Applying hard pressure against the sanding belt causes excessive heat build-up which may "smear" the soft metal over the insulation. After sanding, a clean fine toothed file should be used to dress the squared ends. Each exposed end should be sealed to prevent moisture absorption.

Inexperienced personnel may find 0.032 in. (0.813 mm) or smaller diameter XACTPAK cable difficult to handle and will probably prefer to have all cutting, stripping and fabricating done at the Watlow factory.

Insulation Resistance

XACTPAK mineral insulated, metal-sheathed cable should have a minimum room temperature insulation resistance of 100 megohms when tested at 50VDC for both wires to sheath and wire to wire.

All ceramics used in XACTPAK cable decrease in resistance as temperature increases.

Shipping and Packaging

XACTPAK cable is stocked in random lengths from 20 feet (6 m) to the "Maximum Stock Lengths" listed in the tables on the following pages. We reserve the right to supply random lengths of our choice unless specific cut lengths are specified on the order.

Upon request, XACTPAK cable can be furnished in other coil dimensions or shipped in straight form if necessary. Longer lengths are available for special order.

Stripping

A hand stripping tool will readily remove the sheath from 0.020 through 0.125 in. (3 mm) diameter XACTPAK cable. However, due to difficulty in working with 0.032 in. (0.8 mm) or smaller diameter material, it is recommended that small diameter material be ordered as factory stripped. Material larger than 0.125 in. (3.2 mm) diameter can be stripped on a lathe with a suitable tool bit or lathe-mounted stripping tool. It is also possible to strip larger sizes of XACTPAK cable by using a hacksaw to make a ring cut through the sheath at the desired distance from the end. Hammering the severed portion of sheath at several places will break up the insulation allowing the sheath to be slipped off.

Mineral Insulated Cable

XACTPAK Cable

Technical Data (Continued)

After stripping, the exposed conductors should be sand-blasted or cleaned with emery cloth. The exposed ends should be resealed immediately after completion of the stripping operation.

Forming

Because XACTPAK cable's sheath is dead soft and bright annealed, it can be formed and shaped to most contours without risk of cracking. As a guideline, the sheath can be formed around a mandrel twice the sheath diameter without damage. Therefore, 0.125 in. (3.2 mm) diameter XACTPAK cable can be wound around a 0.250 in. (6 mm) diameter mandrel.

Welding

Due to the delicate nature of the process and to avoid possible contamination, it is recommended that fabrication of "hot" or "measuring" junctions be done at the factory. If attempted in the field, a welding rod made from the same material as the sheath should be used with inert gas. Flux should not be used as it will contaminate the insulation.

Other weldments, such as to a vessel or pipe, should be made in an inert atmosphere to prevent oxidation of the sheath. When working with XACTPAK cable of 0.040 in. (1.0 mm) outside diameter or less, extreme caution should be used not to burn through the sheath.

How to Select XACTPAK Cable to Suit Your Requirements

Watlow's mineral insulated metal-sheathed cable section has been designed for ease of use so that the right cable is chosen for each application. The following four items must be considered when selecting XACTPAK mineral insulated metal-sheathed cable:

1. Sheath Material

The sheath serves to isolate and protect the wires and insulation from contamination and mechanical damage. There is no single sheath material that is appropriate for all conditions, so Watlow offers a wide variety. Temperature, strength, corrosiveness, service life and cost must be considered when selecting a sheath material.

2. Calibration

Watlow stocks most ANSI/ASTM recognized thermocouple types. Watlow also manufactures cable with other wire alloys such as nickel, copper, nickel clad copper, 304 stainless steel, alloy 600 and virtually any malleable metal.

3. Insulation Material

Insulation separates conductors from each other and the outer sheath. When selecting an insulation, temperature rating, environment and cost must be considered.

4. Physical Characteristics

Diameter of the sheath and the wall thickness will directly affect the following:

- Time response
- Service life
- Flexibility
- Pressure rating
- Strength

5. Specify Coil Lengths

Random—the factory selects 20 ft (6 m) minimum.
Special—specify lengths and tolerance. Cut to length charges and minimum order quantities may apply.

Mineral Insulated Cable

XACTPAK Cable

Sheath Material

The following information is designed to be used as a guide and may not be correct for every application. If in doubt, consult with a Watlow sales engineer or contact the factory.

Part Number

①	② ③	④	⑤	⑥ ⑦	⑧ ⑨ ⑩	⑪ ⑫
	Sheath Material	Calibration	Insulation	Sheath O.D.	Variation	Limits of Error
4	Code Below					

Alloy 600

01—Maximum temperature: 2150°F (1175°C). Most widely used thermocouple sheath material. Good high temperature strength, corrosion resistance, resistance to chloride ion stress corrosion cracking and oxidation resistance to high temperatures. Do not use in sulfur bearing environments. Good for use in nitriding environments.

304 SS

02—Maximum temperature: 1650°F (900°C). Most widely used low temperature sheath material. Extensively used in food service, beverage, chemical and other industries where corrosion resistance is required. Subject to damaging carbide precipitation in 900 to 1600°F (480 to 870°C) range. Lowest cost corrosion resistant sheath material available.

316 SS

04—Maximum temperature: 1650°F (900°C). Best corrosion resistance of the austenitic stainless steel grades. Widely used in the food service and chemical industry. Subject to damaging carbide precipitation in 900 to 1600°F (482 to 870°C) range.

Hastelloy® X

18—Maximum temperature: 2200°F (1205°C). Widely used in aerospace applications. Resistant to oxidizing, reducing and neutral atmospheric conditions. Excellent high temperature strength along with superior oxidation resistance. Resistant to stress corrosion cracking in petrochemical applications.

Inconel® 625

25—Maximum temperature: 1800°F (980°C). Used in many aerospace applications. Excellent high temperature strength. Excellent resistance to pitting and crevice corrosion. Unaffected by radiation embrittlement.

Haynes® Alloy 230

32—Maximum temperature: 2150°F (1177°C). This alloy offers excellent high temperature strength, oxidation resistance and long term thermal stability. Used in aerospace applications, chemical process industries and high temperature industrial heating applications. This alloy is recommended for use in nitriding environments.

Mineral Insulated Cable

XACTPAK Cable

Calibration

Part Number

①	② ③	④	⑤	⑥ ⑦	⑧ ⑨ ⑩	⑪ ⑫
	Sheath Material	Calibration Code Below	Insulation	Sheath O.D.	Variation	Limits of Error
4						

ASTM Type J

1—Type J's positive leg (JP) is iron. Its negative leg (JN) is approximately 45 percent nickel-55 percent copper. When protected by compacted mineral insulation and outer sheath, Type J is usable from 32 to 1500°F (0 to 815°C). Type J is not susceptible to short range ordering in the 600 to 1100°F (315 to 593°C) temperature range, (+2 to +4°F drift) which occurs with ASTM Type E and K. This low cost, stable thermocouple calibration is primarily used with 96 percent pure magnesium oxide (MgO) insulation and stainless steel sheath.

ASTM Type K

2—Type K's positive leg (KP) is approximately 90 percent nickel-10 percent chromium. Its negative leg (KN) is approximately 95 percent nickel-two percent aluminum-two percent manganese-one percent silicon. When protected by compacted mineral insulation and outer sheath, Type K is usable from 32 to 2300°F (0 to 1260°C). If the application is 600 to 1100°F (315 to 593°C), we recommend Type J or N due to short range ordering that can cause drift of +2 to +4°F (+1.5 to +2°C) in a few hours time. Type K is relatively stable during radiation transmission in nuclear environments. For applications below 32°F (0°C), special alloy selections are usually required.

ASTM Type T

3—Type T's positive leg (TP) is pure copper. Its negative leg (TN) is approximately 45 percent nickel-55 percent copper. When protected by compacted mineral insulation and outer sheath, Type T is usable from 32 to 660°F (0 to 350°C) and very stable in cryogenic and low temperature applications. For applications below 32°F (0°C) special alloy selections may be required.

ASTM Type E

4—Type E's positive leg (EP) is approximately 90 percent nickel-10 percent chromium. Its negative leg (EN) is approximately 45 percent nickel-55 percent copper. When protected by compacted mineral insulation and outer sheath, Type E is usable from 32 to 1650°F (0 to 900°C) and has the highest electromotive force (EMF) output per degree of all ASTM types. If the application temperature is 600 to 1100°F (315 to 593°C) Type J or N is recommended due to short range ordering which can cause drift of +1 to +3°F in a few hours time. For applications below 32°F (0°C), special alloy selections may be required.

ASTM Type N

8—Type N's positive leg (nicosil) is approximately 14 percent chromium-1.4 percent silicon-84.6 nickel. Its negative leg (nisil) is approximately 4.4 percent silicon-95.6 percent nickel. When protected by compacted mineral insulation and outer sheath, it's usable from 32 to 2300°F (0 to 1260°C). Type N overcomes several problems inherent in Type K. Short range ordering, +2 to +4°F drift (+1.5 to +2°C), in the 600 to 1100°F (315 to 593°C) range is greatly reduced, and drift rate at high temperatures is considerably less. Type N is also more stable than Type K in nuclear environments.

Miscellaneous

9—Contact the factory.

Mineral Insulated Cable

XACTPAK Cable

Insulation

Part Number

①	② ③	④	⑤	⑥ ⑦	⑧ ⑨ ⑩	⑪ ⑫
	Sheath Material	Calibration	Insulation Code Below	Sheath O.D.	Variation	Limits of Error
4						

High Purity Magnesium Oxide (MgO) 99.4 Percent Minimum Purity

1—Low impurity levels make this insulation very useful for all thermocouple calibrations up to 2500°F (1370°C). Above 2500°F (1371°C), Watlow recommends using hafnia oxide insulation because of MgO's low resistivity. This material meets the requirements established in ASTM E-235.

Magnesium Oxide (MgO) 96% Minimum Purity

5—This low cost insulation is similar to high purity MgO (1) except it should be used in applications below 2000°F (1095°C) due to impurity levels. This insulation should not be used with platinum or in nuclear applications.

Mineral Insulated Cable

XACTPAK Cable

Sheath O.D.

Part Number

①	② ③	④	⑤	⑥ ⑦	⑧ ⑨ ⑩	⑪ ⑫
	Sheath Material	Calibration	Insulation	Sheath O.D. Code Below	Variation	Limits of Error
4						

Code	Sheath Diameter		Approximate Standard	Coil Weight lbs/100 ft	Average Response Time* Still Water (seconds)	
	Nominal	Tolerance			G-JCT	U-JCT
01	0.020 inch	+0.001, -0.0005	9 inch	0.08	<0.02	0.03
02	0.032 inch	+0.001, -0.0005	9 inch	0.20	0.02	0.07
03	0.040 inch	+0.001, -0.0005	9 inch	0.32	0.04	0.13
04	0.063 inch	±0.001	24 inch	0.74	0.22	0.40
07	0.125 inch	+0.002, -0.001	24 inch	3.00	0.50	1.10
08	0.188 inch	+0.002, -0.001	24 inch	6.65	1.00	2.30
11	0.250 inch	+0.003, -0.001	24 inch	11.65	2.20	4.10
13	0.375 inch	+0.003, -0.001	Straight or 40 inch coils	28.10	8.00	11.00
15	0.500 inch	+0.003, -0.001	Straight or 40 inch	47.00	15.00	20.00
51	0.5 mm	±0.02	23 cm	0.08	<0.02	0.03
52	1.0 mm	±0.02	23 cm	0.32	0.04	0.13
53	1.5 mm	±0.02	61 cm	0.65	<0.15	0.35
54	2.0 mm	±0.03	61 cm	1.13	0.25	0.55
55	3.0 mm	±0.03	61 cm	2.60	0.40	0.90
56	4.5 mm	±0.03	61 cm	6.00	0.95	2.00
57	6.0 mm	±0.05	61 cm	10.50	2.00	3.50

* Note: First order response time 63.2%

Mineral Insulated Cable

XACTPAK Cable

Variations

Part Number

①	② ③	④	⑤	⑥ ⑦	⑧ ⑨ ⑩	⑪ ⑫
	Sheath Material	Calibration	Insulation	Sheath O.D.	Variation	Limits of Error
4					Code Below	

⑧ ⑨ ⑩	Variation
050 =	Dual adjacent
Note:	leave space blank for no variation

Limits of Error

Part Number

①	② ③	④	⑤	⑥ ⑦	⑧ ⑨ ⑩	⑪ ⑫
	Sheath Material	Calibration	Insulation	Sheath O.D.	Variation	Limits of Error
4						Code Below

⑪ ⑫	Limits of Error
Standard =	Leave blank
SP =	Special limits initial tolerance

XACTPAK Cable

Sheath Material

Extended capabilities go beyond the functionality offered by catalog products. These offerings are only available for large quantity orders.

310 SS

Maximum temperature: 2100°F (1150°C). Mechanical and corrosion resistance, similar to but better than 304 SS. Very good heat resistance. This alloy contains 25 percent chromium, 20 percent nickel. Not as ductile as 304 SS.

347 SS

Maximum temperature: 1600°F (870°C). Similar to 304 SS except nickel niobium stabilized. This alloy is designed to overcome susceptibility to carbide precipitation in the 900 to 1600°F (480 to 870°C) range. Used in aerospace and chemical applications.

446 SS

Maximum temperature: 2100°F (1150°C). Ferritic stainless steel with good resistance to sulfurous atmospheres at high temperatures. Good corrosion resistance to nitric acid, sulfuric acid and most alkalis. 27 percent chromium content gives this alloy the highest heat resistance of any ferritic stainless steel.

321 SS

Maximum temperature: 1600°F (870°C). Similar to 304 SS except titanium stabilized for inter-granular corrosion. This alloy is designed to overcome susceptibility to carbon precipitation in the 900 to 1600°F (480 to 870°C) range. Used in aerospace and chemical applications.

Inconel® 601

Maximum temperature: 2150°F (1175°C) continuous, 2300°F (1260°C) intermittent. Similar to Alloy 600 with the addition of aluminum for outstanding oxidation resistance. Designed for high temperature corrosion resistance. This material is good for use in carburizing environments and exhibits good creep rupture strength. Do not use in vacuum furnaces. Susceptible to intergranular attack by prolonged heating in 1000 to 1400°F (540 to 760°C) temperature range.

Haynes® Alloy HR-160

Maximum temperature: 2150°F (1175°C). Developed to provide superior sulfidation-resistance at high temperatures. This alloy exhibits good resistance to corrosion in some salt bath applications. Used in applications for sulfur furnaces, waste incinerators, coke burners, recuperators, cement kilns and high temperature furnaces.

Haynes® Alloy 718

Maximum temperature: 1300°F (700°C). A precipitation hardenable Inconel® alloy developed for corrosion resistance and excellent weldability. Application uses include gas turbine, aerospace, oil and gas production and nuclear.

Insulation

Alumina Oxide (Al₂O₃) 99.6% Minimum Purity

Although this material is comparable to MgO in its electrical properties and cost, it does not compact well and tends to “powder out.” This undesirable characteristic has made this insulation unpopular, therefore, cable with this type of insulation is available only as a special order.

Hafnia Oxide (HfO₂)

Hafnia is used as a substitute for beryllia oxide (BeO) because of beryllia’s toxicity problem. The temperature limit of hafnia is 4530°F (2500°C), which is higher than BeO.

Variations

- Triple element
- Heavy wall (approximately 20 percent heavier)

Mineral Insulated Cable

XACTPAK Cable

Single Element Cable

Standard Limit Code Number	Special Limits of Error Code Number	Sheath Diameter	Sheath Material	Calibration	Nominal AWG Gauge	Nominal Wall Thickness (in.)	Max. Recommended Operating Temp °F (°C)
401-2101	401-2101-SP	0.020	Alloy 600	K	38	0.003	1600 (871)
401-2102	401-2102-SP	0.032	Alloy 600	K	34	0.004	1600 (871)
401-2103	401-2103-SP	0.040	Alloy 600	K	32	0.006	1600 (871)
402-2103	402-2103-SP	0.040	304 SS	K	32	0.006	1600 (871)
404-2103	404-2103-SP	0.040	316 SS	K	32	0.009	1600 (871)
401-2104	401-2104-SP	0.063	Alloy 600	K	28	0.009	2000 (1093)
N/A	401-2104-HT ^①	0.063	Alloy 600	K	28	0.009	2000 (1093)
404-2104	404-2104-SP	0.063	316 SS	K	28	0.012	1600 (871)
401-2107	401-2107-SP	0.125	Alloy 600	K	22	0.017	2150 (1177)
N/A	401-2107-HT ^①	0.125	Alloy 600	K	22	0.017	2150 (1177)
402-1507	402-1507-SP	0.125	304 SS	J	22	0.017	1500 (816)
402-2507	402-2507-SP	0.125	304 SS	K	22	0.017	1600 (871)
404-2507	404-2507-SP	0.125	316 SS	K	22	0.017	1600 (871)
401-2108	401-2108-SP	0.188	Alloy 600	K	19	0.025	2150 (1177)
402-1508	402-1508-SP	0.188	304 SS	J	19	0.025	1500 (816)
402-2508	402-2508-SP	0.188	304 SS	K	19	0.025	1600 (871)
404-2508	404-2508-SP	0.188	316 SS	K	19	0.025	1600 (871)
401-2111	401-2111-SP	0.250	Alloy 600	K	16	0.033	2150 (1177)
402-1511	402-1511-SP	0.250	304 SS	J	16	0.033	1500 (816)
402-2511	402-2511-SP	0.250	304 SS	K	16	0.033	1600 (871)
404-1511	404-1511-SP	0.250	316 SS	J	16	0.033	1500 (816)
404-2511	404-2511-SP	0.250	316 SS	K	16	0.033	1600 (871)
401-2113	401-2113-SP	0.375	Alloy 600	K	13	0.051	2150 (1177)

^①This cable is designed for heat treat applications where stability and calibration per AMS2750 are required.

Double Element Cable

Standard Limit Code Number	Special Limits of Error Code Number	Sheath Diameter	Sheath Material	Calibration	Nominal AWG Gauge	Nominal Wall Thickness (in.)	Max. Recommended Operating Temp °F (°C)
401-2104-050	401-2104-050-SP	0.063	Alloy 600	K	28	0.009	2000 (1093)
401-2107-050	401-2107-050-SP	0.125	Alloy 600	K	24	0.017	2000 (1093)
401-2108-050	401-2108-050-SP	0.188	Alloy 600	K	21	0.025	2150 (1177)
401-2111-050	401-2111-050-SP	0.250	Alloy 600	K	18	0.033	2150 (1177)

Mineral Insulated Cable

XACTPAK Cable

Mineral Insulated Metal-Sheathed RTD Cable

This cable is used for making rugged resistance temperature detector (RTD) probes. Special spacing allows room for elements to be placed between conductors. Dimensions are shown below.

Ordering Information

Part Number

①	② ③	④	⑤	⑥ ⑦	⑧ ⑨ ⑩
	Sheath Material	Wire	Wire Insulation	Sheath O.D.	Variation
4		9			

② ③	Sheath Material
01 =	Alloy 600
04 =	316 SS

④	Wire
9 =	Nickel 201

⑤	Wire Insulation
1 =	99.4% MgO
5 =	96% MgO

⑥ ⑦	Sheath O.D.
07 =	0.125 in. (3 mm) diameter
08 =	0.188 in. (4.8 mm) diameter
11 =	0.250 in. (6 mm) diameter

⑧ ⑨ ⑩	Variation
001 =	6-wire
003 =	4-wire

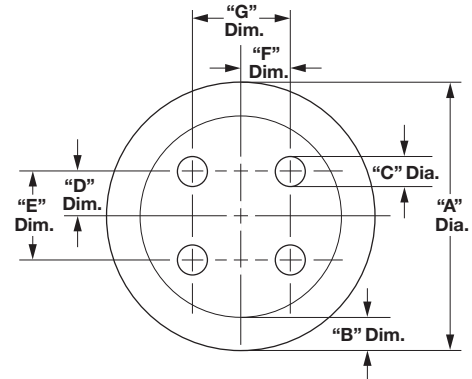

4 Conductor RTD MIMS Cable

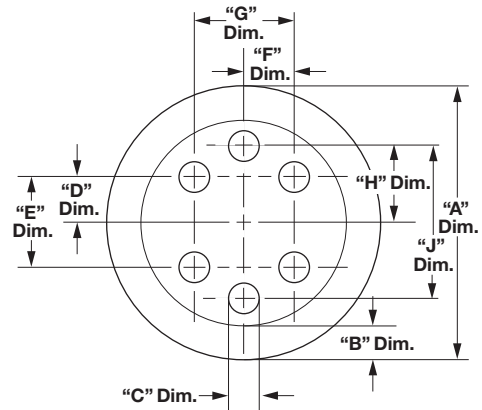

6 Conductor RTD MIMS Cable

A Diameter	B Wall Thickness	C Diameter	Spacing Nominal			
			D Dim.	E Dim.	F Dim.	G Dim.
0.125 +0.002 -0.001	0.015 ± 0.002	0.014 ± 0.002	0.022	0.045	0.025	0.050
0.188 +0.002 -0.001	0.023 ± 0.002	0.020 ± 0.002	0.034	0.068	0.037	0.074
0.250 +0.003 -0.001	0.030 ± 0.005	0.027 ± 0.003	0.045	0.090	0.050	0.100

A Dim.	B Dim.	C Dim.	D Dim.	E Dim.	F Dim.	G Dim.	H Dim.	J Dim.
0.125 +0.002 -0.001	0.015 ± 0.002	0.014 ± 0.002	0.022	0.045	0.025	0.050	0.034	0.068
0.188 +0.002 -0.001	0.023 ± 0.002	0.020 ± 0.002	0.034	0.068	0.037	0.074	0.052	0.104
0.250 +0.003 -0.001	0.030 ± 0.005	0.027 ± 0.003	0.045	0.090	0.050	0.100	0.068	0.137

Mineral Insulated Cable

XACTPAK Cable

Made-to-order
Mineral Insulated (MI) Cable

Ordering Information

Part Number

①	② ③	④	⑤	⑥ ⑦	⑧ ⑨ ⑩	⑪ ⑫
	Sheath Material	Calibration	Insulation	Sheath O.D.	Variation	Limits of Error
4						

② ③	Sheath Material
01 =	Alloy 600
02 =	304 SS
04 =	316 SS
18 =	Hastelloy® X
25 =	Inconel® 625
32 =	Haynes® Alloy 230

④	Calibration
1 =	J
2 =	K
3 =	T
4 =	E
8 =	N

⑤	Insulation
0 =	Unused
1 =	Magnesium oxide 99.4%
5 =	Magnesium oxide 96%

⑥ ⑦	Sheath O.D. in. (mm)
01 =	0.020 (0.6)
02 =	0.032 (0.8)
03 =	0.040 (1.0)
04 =	0.063 (1.6)
07 =	0.125 (3)
08 =	0.188 (4.8)
11 =	0.250 (6)
13 =	0.375 (9.5)
15 =	0.500 (13)

⑧ ⑨ ⑩	Variation
050 =	Dual adjacent — Example: 401-2107-050
Note: leave space blank for no variation	

⑪ ⑫	Limits of Error
SP =	Special limits — Example: 401-2107-SP
Note: leave space blank for standard	